

VEGA 85 AR

Data Sheet

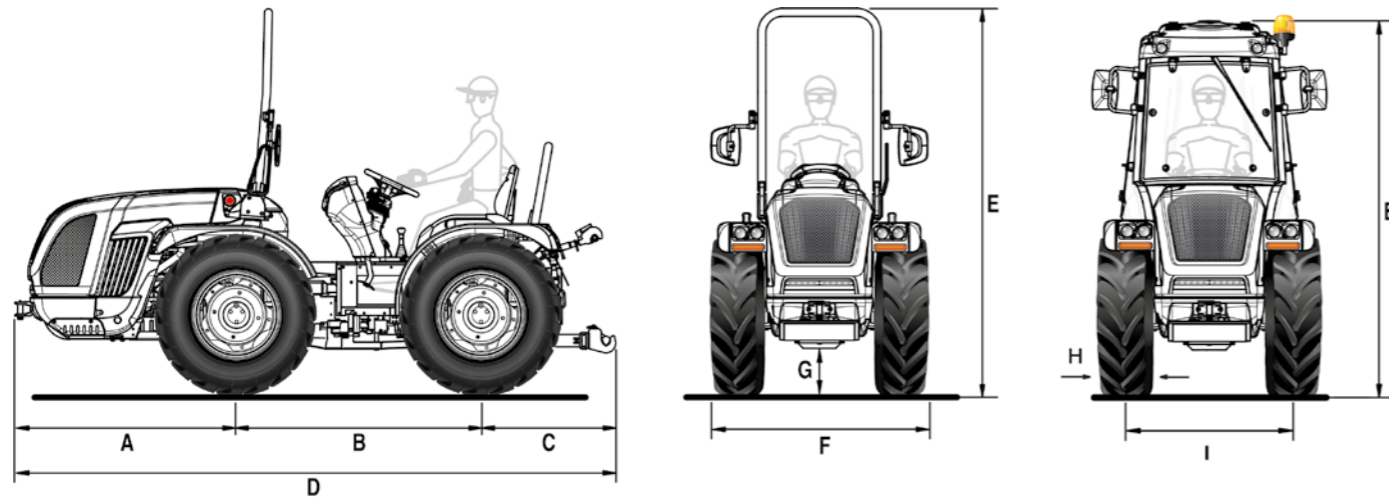

A	B	C	D	E min/max (with roll-bar)	E min/max (with cab)	F min/max	G min/max
1348	1495	932	3775	2254 / 2364	2139 / 2249	1127 / 1603	161 / 271

* Dimensions in mm

	250/80-18	280/70 R18	280/70 R18 Galaxy Garden	320/65 R18	250/85 R20
	with adjustable rim	with adjustable rim	with adjustable rim	with adjustable rim	with adjustable rim
H	240	282	282	320	245
I	898 / 1112	1022 / 1112	1022 / 1112	1022 / 1112	882 / 1230
F	1138 / 1352	1304 / 1394	1304 / 1394	1342 / 1432	1127 / 1475

	300/70 R20	300/70 R20 Galaxy Garden	340/65 R20	31x15.50-15 XTC	33x12.50-15 T413
	with adjustable rim	with adjustable rim	with adjustable rim	with fixed rim	with fixed rim
H	286	286	343	368	325
I	996 / 1260	996 / 1260	996 / 1260	1016	959 / 965
F	1282 / 1546	1282 / 1546	1339 / 1603	1384	1284 / 1290

* Dimensions in mm - min / max
H = Tyre width - I = Wheel track - F = Tractor width

TECHNICAL FEATURES	VEGA 85 AR
ENGINE	Kohler KDI 2504 TCR
No. of cylinders	4 in-line / 16 valves
Displacement (cc)	2482
Intake	Turbo / Intercooler
Fuel system	"Common rail" direct injection - 2000 bar
Emissions compliance	Stage V
Balancing	Counter-balance shafts
Power (kW/hp)	55.4 / 75.3
Rated speed (rpm)	2300
Max torque (Nm/rpm)	300 / 1500
Engine speed management	Electronically regulated via a console with functions for: increase and decrease engine speed, memorize and recall the set speed, switch off and switch to minimum speed
Cooling	Liquid
Tank capacity (l)	58
CHASSIS	Swinging integral chassis (±15°) OS-FRAME with central articulation
DRIVE	Four-wheel drive. Front-wheel drive disengagement with electro-hydraulic control
TRANSMISSION	32-speed synchronised gearbox: 16 FWD and 16 REV with synchronised reverser
Min/max travel speed (km/h)	0.7 / 38
POWER SHUTTLE EASYDRIVE® (optional)	Electro-hydraulic power shuttle electronically actuated with the lever (three-position FWD-N-REV) located on the left of steering wheel. Possibility to choose from 5 levels of reactivity
Transmission clutch	Multidisc in oil bath with electronically-managed and proportional hydraulic control. Power Clutch System button for engaging gears and reverser without using the clutch pedal. PRO-ACT System clutch pedal with Easy Plus™ assisted engagement. Smart Brake & Go function for automatic clutch management only with the brake pedal.
DIFFERENTIAL	Front and rear. Differential lock: front and rear simultaneously or rear only with electro-hydraulic control
AXLES	Front and rear with planetary reduction units
REAR PTO	Independent from the gearbox and synchronised with the forwarding speed. Negative safety hydraulic brake to stop the PTO
PTO clutch	Multidisc in oil bath with electro-hydraulic control
PTO rotation speed (rpm)	Standard: 540/540E - Optional: 540/1000
HYDRAULIC SYSTEM	Dual circuit with independent pumps and heat exchanger
Flow rate to the hydroguide and the electro-hydraulic controls (l/min)	33.5
Flow rate to the lift and the control valves (l/min)	29.5 (optional oversized pump with 51 l/min flow rate)
Maximum hydraulic pressure (bar)	180
REAR CONTROL VALVES	Mechanically controlled
Standard	2 double-acting + free flow oil return (total 5 hydraulic outlets)
Optional and in addition to the standard ones	1 single-acting and 1 double-acting (8 hydraulic outlets in total) or 1 double-acting and 1 double-acting with float (total 9 hydraulic outlets)
Joystick (optional)	Proportional electronic control of lifts and rear control valves consisting of: 1 continuous flow with adjustable flow rate and free flow oil return, 5 double-acting (replacing the standard ones) and oversized pump. Potentiometer for adjusting joystick sensitivity. Remote control for PTO engagement. Storage armrest
REAR LIFT	By two external rams. Standard: raising/lowering - Optional: position and draft control
3-point implement hitch	Standard: Normal couplings cat. 1 and 2. Optional: Quick-couplings cat. 1 and 2, L-shaped, arms adjustable in length and hooks adjustable in width
Third point tie rod	Standard: with manual adjustment - Optional: hydraulically controlled upper link and tie rod link arm
Ball joint lifting capacity (kg)	2300
FRONT LIFT (optional)	Two rams with front protection and 2 double-acting control valves (total 4 front hydraulic outlets)
Third point arms	Rigid with quick-couplings cat. 1 and 2
Lifting capacity (kg)	800
DRIVING POSITION	Reversible with rotating platform suspended on silent blocks. Suspended pedals mounted on the rotating control tower
Steering wheel	Tilt adjustable
Seat	With gas spring for easy tipping, safety belt and man-on-board sensor. - Standard: comfort seat with adjustable spring tension according to the operator's weight - Optional: 'Kab Seating', 'Grammer' or 'Cobo' pneumatic seat
SERVICE BRAKES	Oil bath discs with hydrostatic control, acting on the four wheels with automatic engagement of the 4-wheel drive
Parking brake	Automatic and independent Brake-Off acting as emergency brake with proportional action
STEERING	Hydrostatic steering acting on the central joint. Flow deviator for steering unit
SAFETY	Standard: front homologated roll-bar with gas springs for easy lowering and lifting
CABIN (optional)	VISTA CLIMA with 4-upright and conical structure, homologated and soundproofed with monocoque body mounted on silent-blocks, beacon lamp and fabric seat. Ventilation, heating and air-conditioning system. Car radio preparation. Optional: active carbon filters
DASHBOARD	With TFT colour display showing: hours of operation, engine rpm, forwarding speed, PTO rpm, particulate filter clogging level, instantaneous fuel consumption, battery voltage and current time. Analogue instrumentation complete with engine rpm, engine coolant temperature and fuel level indicator. Warning lights and acoustic alarm
ELECTRIC SYSTEM	Battery 80 Ah / 12 V - Alternator 95 A
Standard equipment	Vehicle Control Unit, street light and indicator system, front LED working lights, single-pole dashboard socket, rear 7-pin and 3-pin sockets
TYRES	250/80-18 * 280/70R18 * 280/70R18 Galaxy Garden * 320/65R18 * 250/85R20 * 300/70R20 * 300/70R20 Galaxy Garden * 340/65R20 * 31x15.50-15 XTC * 33x12.50-15 T413
TOW HOOKS (standard)	Front - Rear CUNA cat. C adjustable in height
Optional	Rear tow hook: EC approved or EC with Slider frame or CUNA with Slider frame or EC tow bar with Slider frame
RUNNING ORDER WEIGHT	With roll-bar (kg): 2240 kg - With cab: 2390 kg
ADDITIONAL OPTIONS	Front bumper, beacon lamp, rear adjustable working light, Self Cleaning System™, front weights 150 kg and wheel weights 50 kg each, anti-dumping system, black and white 'Special Edition' livery

VEGA 85 RS

Data Sheet

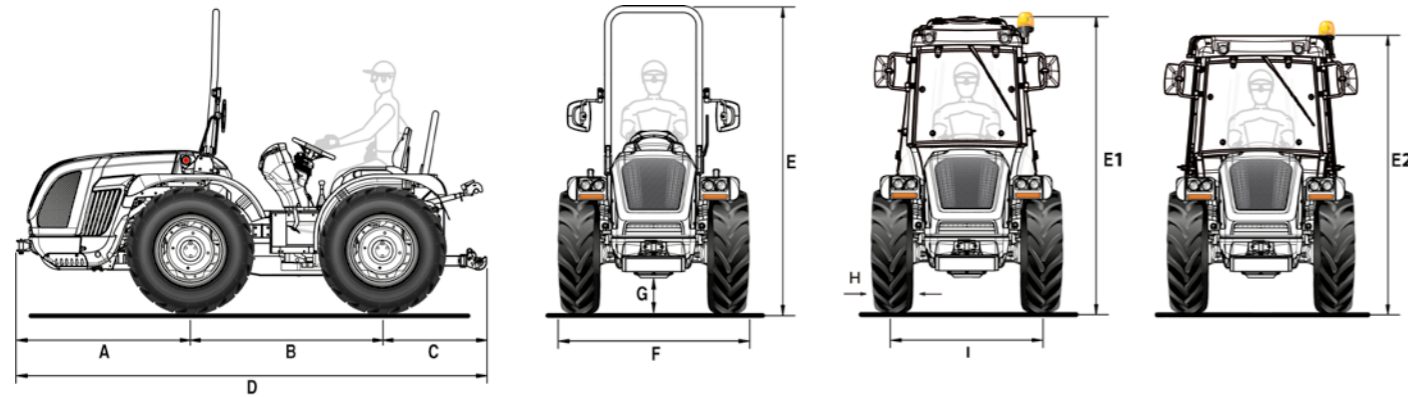

A	B	C	D	E min/max (with roll-bar)	E1 min/max (with VISTA cab)	E2 min/max (with SPACE cab)	F min/max	G min/max
1348	1495	932	3775	2254 / 2364	2139 / 2249	2070 / 2180	1296 / 1961	161 / 271

* Dimensions in mm

	340/65 R18	280/70 R18	280/70 R18 Galaxy Garden	320/65 R18	250/85 R20	300/70 R20	300/70R20 Galaxy Garden
	with adjustable rim	with adjustable rim	with adjustable rim	with adjustable rim	with adjustable rim	with adjustable rim	with adjustable rim
H	343	282	282	320	245	286	286
I	1166 / 1470	1098 / 1538	1098 / 1538	1166 / 1470	1046 / 1588	1134 / 1618	1134 / 1618
F	1509 / 1813	1380 / 1820	1380 / 1820	1486 / 1790	1296 / 1838	1420 / 1904	1420 / 1904

	320/70 R20	340/65 R20	31x15.50-15 XTC	31x15.50-15 STG	33x15.50-15 XTC	13.6-16 Garden
	with adjustable rim	with adjustable rim	with fixed rim	with fixed rim	with fixed rim	with fixed rim
H	316	343	368	394	391	391
I	1134 / 1618	1134 / 1618	1260 / 1374	1260 / 1374	1260 / 1374	1240 / 1400
F	1450 / 1934	1477 / 1961	1628 / 1742	1654 / 1768	1651 / 1765	1631 / 1791

* Dimensions in mm - min / max
H = Tyre width - I = Wheel track - F = Tractor width

TECHNICAL FEATURES	VEGA 85 RS
ENGINE	Kohler KDI 2504 TCR
No. of cylinders	4 in-line / 16 valves
Displacement (cc)	2482
Intake	Turbo / Intercooler
Fuel system	"Common rail" direct injection - 2000 bar
Emissions compliance	Stage V
Balancing	Counter-balance shafts
Power (kW/hp)	55.4 / 75.3
Rated speed (rpm)	2300
Max torque (Nm/rpm)	300 / 1500
Engine speed management	Electronically regulated via a console with functions for: increase and decrease engine speed, memorize and recall the set speed, switch off and switch to minimum speed
Cooling	Liquid
Tank capacity (l)	58
CHASSIS	Swinging integral chassis (±15°) OS-FRAME with steering wheels
DRIVE	Four-wheel drive. Front-wheel drive disengagement with electro-hydraulic control
TRANSMISSION	32-speed synchronised gearbox: 16 FWD and 16 REV with synchronised reverser
Min/max travel speed (km/h)	0.7 / 40
POWER SHUTTLE EASYDRIVE® (optional)	Electro-hydraulic power shuttle electronically actuated with the lever (three-position FWD-N-REV) located on the left of steering wheel. Possibility to choose from 5 levels of reactivity
Transmission clutch	Multidisc in oil bath with electronically-managed and proportional hydraulic control. - Power Clutch System button for engaging gears and reverser without using the clutch pedal. - PRO-ACT System clutch pedal with Easy Plus™ assisted engagement. - Smart Brake & Go function for automatic clutch management only with the brake pedal.
DIFFERENTIAL	Front and rear. Differential lock: front and rear simultaneously or rear only with electro-hydraulic control
AXLES	Front and rear with planetary reduction units
REAR PTO	Independent from the gearbox and synchronised with the forwarding speed. Negative safety hydraulic brake to stop the PTO
PTO clutch	Multidisc in oil bath with electro-hydraulic control
PTO rotation speed (rpm)	Standard: 540/540E - Optional: 540/1000
HYDRAULIC SYSTEM	Dual circuit with independent pumps and heat exchanger
Flow rate to the hydroguide and the electro-hydraulic controls (l/min)	33.5
Flow rate to the lift and the control valves (l/min)	29.5 (optional oversized pump with 51 l/min flow rate)
Maximum hydraulic pressure (bar)	180
REAR CONTROL VALVES	Mechanically controlled
Standard	2 double-acting + free flow oil return (total 5 hydraulic outlets)
Optional and in addition to the standard ones	1 single-acting and 1 double-acting (8 hydraulic outlets in total) or 1 double-acting and 1 double-acting with float (total 9 hydraulic outlets)
Joystick (optional)	Proportional electronic control of lifts and rear control valves consisting of: 1 continuous flow with adjustable flow rate and free flow oil return, 5 double-acting (replacing the standard ones) and oversized pump. Potentiometer for adjusting joystick sensitivity. Remote control for PTO engagement. Storage armrest
REAR LIFT	By two external rams. Standard: raising/lowering - Optional: position and draft control
3-point implement hitch	Standard: Normal couplings cat. 1 and 2. Optional: Quick-couplings cat. 1 and 2, arms adjustable in length or Quick-couplings cat. 1 and 2, L-shaped, arms adjustable in length and hooks adjustable in width
Third point tie rod	Standard: with manual adjustment - Optional: hydraulically controlled upper link and tie rod link arm
Ball joint lifting capacity (kg)	2300
FRONT LIFT (optional)	Two rams with front protection and 2 double-acting control valves (total 4 front hydraulic outlets)
Third point arms	Rigid with quick-couplings cat. 1 and 2
Lifting capacity (kg)	800
DRIVING POSITION	Reversible with rotating platform suspended on silent blocks. Suspended pedals mounted on the rotating control tower
Steering wheel	Tilt adjustable
Seat	With gas spring for easy tipping, safety belt and man-on-board sensor. - Standard: comfort seat with adjustable spring tension according to the operator's weight - Optional: 'Kab Seating', 'Grammer' or 'Cobo' pneumatic seat
SERVICE BRAKES	Oil bath discs with hydrostatic control, acting on the four wheels with automatic engagement of the 4-wheel drive. Independent manoeuvring brakes acting on the rear wheels
Parking brake	Automatic and independent Brake-Off acting as emergency brake with proportional action
STEERING	Hydrostatic steering acting on the front wheels. Flow deviator for steering unit
SAFETY	Standard: front homologated roll-bar with gas springs for easy lowering and lifting
CABIN (optional)	Homologated and soundproof with monocoque body mounted on silent-blocks, beacon lamp and fabric seat. Ventilation, heating and air-conditioning system. Car radio preparation. Available with 6-upright structure (SPACE CLIMA) or 4-upright conical structure (VISTA CLIMA). Optional: active carbon filters
DASHBOARD	With TFT colour display showing: hours of operation, engine rpm, forwarding speed, PTO rpm, particulate filter clogging level, instantaneous fuel consumption, battery voltage and current time. Analogue instrumentation complete with engine rpm, engine coolant temperature and fuel level indicator. Warning lights and acoustic alarm
ELECTRIC SYSTEM	Battery 80 Ah / 12 V - Alternator 95 A
Standard equipment	Vehicle Control Unit, street light and indicator system, front LED working lights, single-pole dashboard socket, rear 7-pin and 3-pin sockets
TYRES	340/65R18 * 280/70R18 * 280/70R18 Galaxy Garden * 320/65R18 * 250/85R20 * 300/70R20 * 300/70R20 Galaxy Garden * 320/70R20 * 340/65R20 * 31x15.50-15 XTC or STG * 33x15.50-15 XTC * 13.6-16 Garden
TOW HOOKS (standard)	Front - Rear CUNA cat. C adjustable in height
Optional	Rear tow hook: EC approved or EC with Slider frame or CUNA with Slider frame or EC tow bar with Slider frame
RUNNING ORDER WEIGHT	With roll-bar (kg): 2320 kg - With cab: 2470 kg
ADDITIONAL OPTIONS	HDR hydraulic suspension with accumulator including: 2 double-acting (control valves replacing the standard ones), front bumper, beacon lamp, rear adjustable working light, Self Cleaning System™, front weights 150 kg and wheel weights 50 kg each, anti-dumping system, black and white 'Special Edition' livery

VEGA 85 DUALSTEER®

Data Sheet

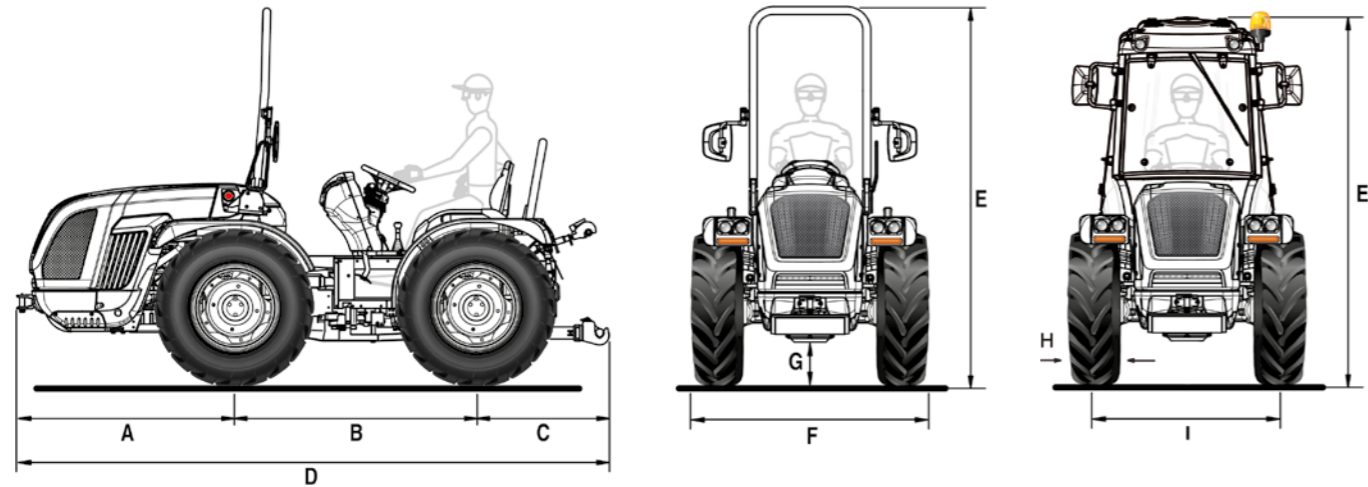

A	B	C	D	E min/max (with roll-bar)	E min/max (with cab)	F min/max	G min/max
1348	1495	932	3775	2254 / 2364	2139 / 2249	1296 / 1961	161 / 271

* Dimensions in mm

	340/65 R18	280/70 R18	280/70 R18 Galaxy Garden	320/65 R18	250/85 R20	300/70 R20
	with adjustable rim	with adjustable rim	with adjustable rim	with adjustable rim	with adjustable rim	with adjustable rim
H	343	282	282	320	245	286
I	1166 / 1470	1098 / 1538	1098 / 1538	1166 / 1470	1046 / 1588	1134 / 1618
F	1509 / 1813	1380 / 1820	1380 / 1820	1486 / 1790	1296 / 1838	1420 / 1904

	300/70R20 Galaxy Garden	320/70 R20	340/65 R20	31x15.50-15 XTC	31x15.50-15 STG	33x15.50-15 XTC
	with adjustable rim	with adjustable rim	with adjustable rim	with fixed rim	with fixed rim	with fixed rim
H	286	316	343	368	394	391
I	1134 / 1618	1134 / 1618	1134 / 1618	1260 / 1374	1260 / 1374	1260 / 1374
F	1420 / 1904	1450 / 1934	1477 / 1961	1628 / 1742	1654 / 1768	1651 / 1765

* Dimensions in mm - min / max
H = Tyre width - I = Wheel track - F = Tractor width

TECHNICAL FEATURES	VEGA 85 DUALSTEER®
ENGINE	Kohler KDI 2504 TCR
No. of cylinders	4 in-line / 16 valves
Displacement (cc)	2482
Intake	Turbo / Intercooler
Fuel system	"Common rail" direct injection - 2000 bar
Emissions compliance	Stage V
Balancing	Counter-balance shafts
Power (kW/hp)	55.4 / 75.3
Rated speed (rpm)	2300
Max torque (Nm/rpm)	300 / 1500
Engine speed management	Electronically regulated via a console with functions for: increase and decrease engine speed, memorize and recall the set speed, switch off and switch to minimum speed
Cooling	Liquid
Tank capacity (l)	58
CHASSIS	Swinging integral chassis (±15°) OS-FRAME with central articulation and steering wheels
DRIVE	Four-wheel drive. Front-wheel drive disengagement with electro-hydraulic control
TRANSMISSION	32-speed synchronised gearbox: 16 FWD and 16 REV with synchronised reverser
Min/max travel speed (km/h)	0.7 / 40
POWER SHUTTLE EASYDRIVE® (optional)	Electro-hydraulic power shuttle electronically actuated with the lever (three-position FWD-N-REV) located on the left of steering wheel. Possibility to choose from 5 levels of reactivity
Transmission clutch	Multidisc in oil bath with electronically-managed and proportional hydraulic control. Power Clutch System button for engaging gears and reverser without using the clutch pedal. PFO-ACT System clutch pedal with Easy Plus™ assisted engagement. Smart Brake & Go function for automatic clutch management only with the brake pedal.
DIFFERENTIAL	Front and rear. Differential lock: front and rear simultaneously or rear only with electro-hydraulic control
AXLES	Front and rear with planetary reduction units
REAR PTO	Independent from the gearbox and synchronised with the forwarding speed. Negative safety hydraulic brake to stop the PTO
PTO clutch	Multidisc in oil bath with electro-hydraulic control
PTO rotation speed (rpm)	Standard: 540/540E - Optional: 540/1000
HYDRAULIC SYSTEM	Dual circuit with independent pumps and heat exchanger
Flow rate to the hydroguide and the electro-hydraulic controls (l/min)	33.5
Flow rate to the lift and the control valves (l/min)	29.5 (optional oversized pump with 51 l/min flow rate)
Maximum hydraulic pressure (bar)	180
REAR CONTROL VALVES	Mechanically controlled
Standard	2 double-acting + free flow oil return (total 5 hydraulic outlets)
Optional and in addition to the standard ones	1 single-acting and 1 double-acting (8 hydraulic outlets in total) or 1 double-acting and 1 double-acting with float (total 9 hydraulic outlets)
Joystick (optional)	Proportional electronic control of lifts and rear control valves consisting of: 1 continuous flow with adjustable flow rate and free flow oil return, 5 double-acting (replacing the standard ones) and oversized pump. Potentiometer for adjusting joystick sensitivity. Remote control for PTO engagement. Storage armrest
REAR LIFT	By two external rams. Standard: raising/lowering - Optional: position and draft control
3-point implement hitch	Standard: Normal couplings cat. 1 and 2. Optional: Quick-couplings cat. 1 and 2, arms adjustable in length or Quick-couplings cat. 1 and 2, L-shaped, arms adjustable in length and hooks adjustable in width
Third point tie rod	Standard: with manual adjustment - Optional: hydraulically controlled upper link and tie rod link arm
Ball joint lifting capacity (kg)	2300
FRONT LIFT (optional)	Two rams with front protection and 2 double-acting control valves (total 4 front hydraulic outlets)
Third point arms	Rigid with quick-couplings cat. 1 and 2
Lifting capacity (kg)	800
DRIVING POSITION	Reversible with rotating platform suspended on silent blocks. Suspended pedals mounted on the rotating control tower
Steering wheel	Tilt adjustable
Seat	With gas spring for easy tipping, safety belt and man-on-board sensor. - Standard: comfort seat with adjustable spring tension according to the operator's weight - Optional: 'Kab Seating', 'Grammer' or 'Cobo' pneumatic seat
SERVICE BRAKES	Oil bath discs with hydrostatic control, acting on the four wheels with automatic engagement of the 4-wheel drive. Independent manoeuvring brakes acting on the rear wheels
Parking brake	Automatic and independent Brake-Off acting as emergency brake with proportional action
STEERING	Double steering system Dualsteer® with 4-cylinders. Hydrostatic steering acting on front wheels and central joint. Flow deviator for steering unit
SAFETY	Standard: front homologated roll-bar with gas springs for easy lowering and lifting
CABIN (optional)	VISTA CLIMA with 4-upright and conical structure, homologated and soundproofed with monocoque body mounted on silent-blocks, beacon lamp and fabric seat. Ventilation, heating and air-conditioning system. Car radio preparation. Optional: active carbon filters
DASHBOARD	With TFT colour display showing: hours of operation, engine rpm, forwarding speed, PTO rpm, particulate filter clogging level, instantaneous fuel consumption, battery voltage and current time. Analogue instrumentation complete with engine rpm, engine coolant temperature and fuel level indicator. Warning lights and acoustic alarm
ELECTRIC SYSTEM	Battery 80 Ah / 12 V - Alternator 95 A
Standard equipment	Vehicle Control Unit, street light and indicator system, front LED working lights, single-pole dashboard socket, rear 7-pin and 3-pin sockets
TYRES	340/65R18 * 280/70R18 * 280/70R18 Galaxy Garden * 320/65R18 * 250/85R20 * 300/70R20 * 300/70R20 Galaxy Garden * 320/70R20 * 340/65R20 * 31x15.50-15 XTC or STG * 33x15.50-15 XTC
TOW HOOKS (standard)	Front - Rear CUNA cat. C adjustable in height
Optional	Rear tow hook: EC approved or EC with Slider frame or CUNA with Slider frame or EC tow bar with Slider frame
RUNNING ORDER WEIGHT	With roll-bar (kg): 2390 kg - With cab: 2540 kg
ADDITIONAL OPTIONS	HDR hydraulic suspension with accumulator including: 2 double-acting (control valves replacing the standard ones), front bumper, beacon lamp, rear adjustable working light, Self Cleaning System™, front weights 150 kg and wheel weights 50 kg each, anti-dumping system, black and white 'Special Edition' livery

VEGA 85 MT

Data Sheet

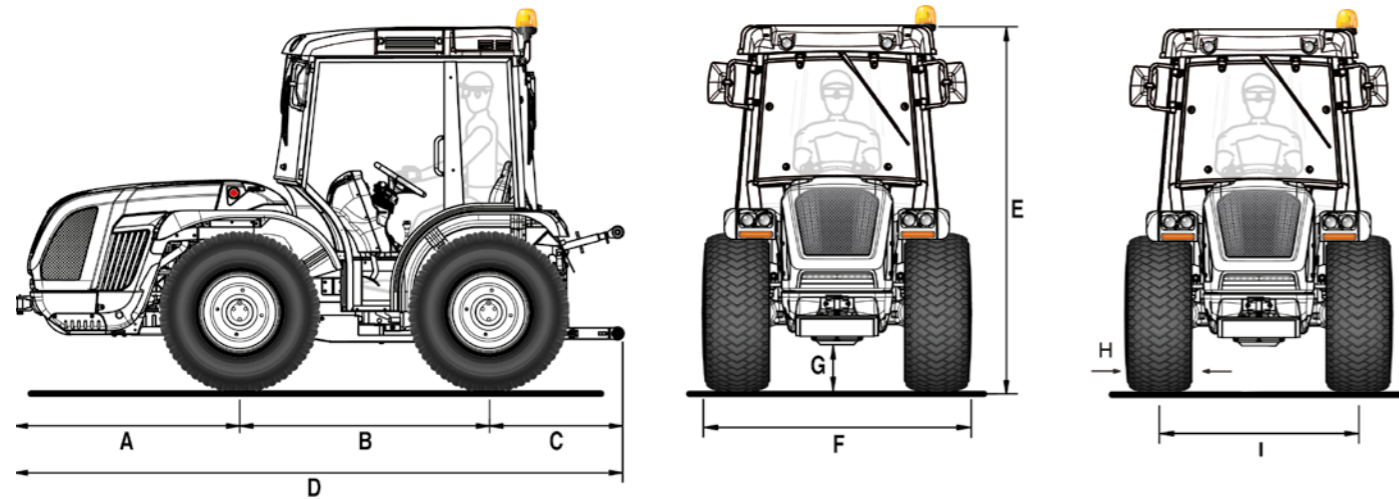

A	B	C	D	E min/max	F min/max	G min/max
1348	1495	932	3775	2070 / 2180	1697 / 1961	161 / 271

* Dimensions in mm

	31x15.50-15 XTC	31x15.50-15 STG	33x15.50-15 XTC	440/50 R17 All-Ground	340/65 R20
	with fixed rim	with fixed rim	with fixed rim	with fixed rim	with adjustable rim
H	368	394	391	431	343
I	1510	1510	1510	1476	1354 / 1618
F	1878	1904	1901	1907	1697 / 1961

* Dimensions in mm - min / max
H = Tyre width - I = Wheel track - F = Tractor width

TECHNICAL FEATURES	VEGA 85 MT
ENGINE	Kohler KDI 2504 TCR
No. of cylinders	4 in-line / 16 valves
Displacement (cc)	2482
Intake	Turbo / Intercooler
Fuel system	"Common rail" direct injection - 2000 bar
Emissions compliance	Stage V
Balancing	Counter-balance shafts
Power (kW/hp)	55.4 / 75.3
Rated speed (rpm)	2300
Max torque (Nm/rpm)	300 / 1500
Engine speed management	Electronically regulated via a console with functions for: increase and decrease engine speed, memorize and recall the set speed, switch off and switch to minimum speed
Cooling	Liquid
Self Cleaning System™	Automatic radiator and engine intake grille cleaning system to prevent overheating
Tank capacity (l)	58
CHASSIS	Swinging integral chassis (±15°) OS-FRAME with steering wheels
DRIVE	Four-wheel drive. Front-wheel drive disengagement with electro-hydraulic control
TRANSMISSION	32-speed synchronised gearbox: 16 FWD and 16 REV with synchronised reverser
Min/max travel speed (km/h)	0.7 / 40
POWER SHUTTLE EASYDRIVE® (optional)	Electro-hydraulic power shuttle electronically actuated with the lever (three-position FWD-N-REV) located on the left of steering wheel. Possibility to choose from 5 levels of reactivity
Transmission clutch	Multidisc in oil bath with electronically-managed and proportional hydraulic control. Power Clutch System button for engaging gears and reverser without using the clutch pedal. PRO-ACT System clutch pedal with Easy Plus™ assisted engagement. Smart Brake & Go function for automatic clutch management only with the brake pedal.
DIFFERENTIAL	Front and rear. Differential lock: front and rear simultaneously or rear only with electro-hydraulic control
AXLES	Front and rear with planetary reduction units
REAR PTO	Independent from the gearbox and synchronised with the forwarding speed. Negative safety hydraulic brake to stop the PTO
PTO clutch	Multidisc in oil bath with electro-hydraulic control
PTO rotation speed (rpm)	Standard: 540/1000
HYDRAULIC SYSTEM	Dual circuit with independent pumps and heat exchanger
Flow rate to the hydroguide and the electro-hydraulic controls (l/min)	33.5
Flow rate to the lift and the control valves (l/min)	29.5
Maximum hydraulic pressure (bar)	180
REAR CONTROL VALVES	Mechanically controlled
Standard	1 single-acting and 2 double-acting + free flow oil return (total 6 hydraulic outlets)
Optional and in addition to the standard ones	1 single-acting (total of 7 hydraulic outlets) or 1 double-acting (total of 8 hydraulic outlets) or 1 double-acting with float (total of 8 hydraulic outlets)
Joystick (optional)	Proportional electronic control of lifts and rear control valves consisting of: 1 single-acting and 3 double-acting (replacing the standard ones). Potentiometer for adjusting joystick sensitivity. Remote control for PTO engagement. Storage armrest
REAR LIFT	Four external rams with Dual Floating System® hydraulic suspension
3-point implement hitch	Quick-couplings cat. 1 and 2, L-shaped, arms adjustable in length and hooks adjustable in width
Third point tie rod	Standard: with manual adjustment - Optional: hydraulically controlled upper link and tie rod link arm
Ball joint lifting capacity (kg)	2300
FRONT LIFT (optional)	Two rams with front protection and 2 double-acting control valves (total 4 front hydraulic outlets)
Third point arms	Rigid with quick-couplings cat. 1 and 2
Lifting capacity (kg)	800
DRIVING POSITION	Wide platform suspended on silent blocks, reversible driver's seat with suspended pedals mounted on rotating control tower
Steering wheel	Tilt adjustable
Seat	With gas spring for easy tipping, safety belt and man-on-board sensor. - Standard: comfort seat with adjustable spring tension according to the operator's weight - Optional: 'Grammer' or 'Cobo' pneumatic seat
SERVICE BRAKES	Oil bath discs with hydrostatic control, acting on the four wheels with automatic engagement of the 4-wheel drive. Independent manoeuvring brakes acting on the rear wheels
Parking brake	Automatic and independent Brake-Off acting as emergency brake with proportional action
STEERING	Hydrostatic steering acting on the front wheels. Flow deviator for steering unit
SAFETY	Standard: 6-upright semi-cab and beacon lamp
CABIN (optional)	SPACE CLIMA with 6-upright, homologated and soundproofed with monocoque body mounted on silent blocks, beacon lamp and fabric seat. Ventilation, heating and air-conditioning system. Car radio preparation. Optional: active carbon filters
DASHBOARD	With TFT colour display showing: hours of operation, engine rpm, forwarding speed, PTO rpm, particulate filter clogging level, instantaneous fuel consumption, battery voltage and current time. Analogue instrumentation complete with engine rpm, engine coolant temperature and fuel level indicator. Warning lights and acoustic alarm
ELECTRIC SYSTEM	Battery 80 Ah / 12 V - Alternator 95 A
Standard equipment	Vehicle Control Unit, street light and indicator system, front LED working lights, single-pole dashboard socket, rear 7-pin and 3-pin sockets
TYRES	31x15.50-15 XTC or STG * 33x15.50-15 XTC * 440/50-17 All-Ground * 340/65R20
TOW HOOKS (standard)	Front - Rear CUNA cat. C adjustable in height
Optional	Rear tow hook: EC approved or EC with Slider frame or CUNA with Slider frame or EC tow bar with Slider frame
RUNNING ORDER WEIGHT	With roll-bar (kg): 2420 kg - With cab: 2500 kg
ADDITIONAL OPTIONS	Front bumper, front weights 150 kg and wheel weights 50 kg each, anti-dumping system, black and white 'Special Edition' livery